

## SCHNELL SINGLE SECTION WALL MOUNTED CABINET

SCHNELL Single Section Wall Mount Cabinets are ideal for office and network environments. Constructed from 1.2mm SPCC cold rolled steel and powder-coated for durability, these cabinets support 19" standard equipment with welded frames, removable side panels, and cable entry from both top and bottom. Available in multiple U sizes with secure locking front doors and easy mounting.



### DIAGRAM & CONSTRUCTION

Frame & Panels	: 1.2mm SPCC Cold Rolled Steel
Front Door	: 5mm Toughened Glass with Steel Frame
	: Single Perforated (Optional)

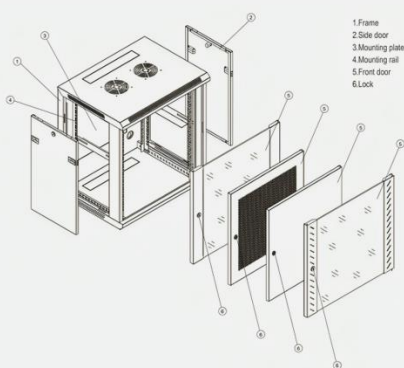

Cable Entry Cover	: Powder Coated Steel
Screws & Nuts	: Zinc Plated Steel

### SURFACE COATING & COLOR

All Steel Parts	: Powder Coated
Color	: Black (Standard)

### PHYSICAL CHARACTERISTICS

Mount Type	: Wall Mounted
Installation Width	: 19"
Door Opening Angle	: 180°
U Sizes Available	: 4U, 6U, 9U, 12U, 15U
Width x Depth (mm)	: 600 x 450 or 600
Height Range (mm)	: 279 to 769 mm

### KEY FEATURES

- Welded steel frame with powder-coated finish
- Cable entry from top and bottom
- 180° front door opening with lock
- Removable side panels for easy access

### KEY APPLICATIONS

- Office and commercial data networking
- Wall-mounted telecom & server installations
- CCTV and IP surveillance housing
- Network switch and patch panel integration

### REACTION TO FIRE

IEC 60754-1/2	: Low smoke & halogen
ISO 9001	: Manufacturing Quality
IEC 60332-1	: Flame Retardant
IEC 61034	: Low Smoke Emission

### STANDARDS

- IEC 61754-20 (LC), IEC 61754-4 (SC)
- ISO/IEC 11801
- EN 50173, TIA/EIA-568
- RoHS and REACH Compliant

### ACCESSORIES

Accessory	Description	Material	Quantity
Front Glass Door	5 mm toughened glass with steel frame	1.2 mm SPCC powder-coated steel	1 piece
Mounting Profile	Internal rail for 19" mounting	1.2 mm SPCC powder-coated steel	1 piece
Cable Entry Cover	Covers for top/bottom cable entries	1.2 mm SPCC powder-coated steel	1 piece
Lock with 2 Keys	Security lockset for front door	Steel / Zinc-plated components	1 set
Frame (Welded Structure)	Cabinet housing structure and chassis	1.2 mm SPCC powder-coated steel	1 piece
Side Panel	Removable for maintenance access	1.2 mm SPCC powder-coated steel	2 pieces
Allen Wrench	Tool included for installation	Steel, black coating	1 piece
M6 Screws & Nuts	Fasteners for mounting profile and panels	Zinc-plated steel	~10 sets

### PART NUMBER

Part Number	Description	Dimensions (mm)
SCZ-1010W64504	SCHNELL 4U 600/450 SINGLE SECTION CABINET	600 X 450 X 279
SCZ-1010W64506	SCHNELL 6U 600/450 SINGLE SECTION CABINET	600 X 450 X 368
SCZ-1010W64509	SCHNELL 9U 600/450 SINGLE SECTION CABINET	600 X 450 X 501
SCZ-1010W64512	SCHNELL 12U 600/450 SINGLE SECTION CABINET	600 X 450 X 635
SCZ-1010W64515	SCHNELL 15U 600/450 SINGLE SECTION CABINET	600 X 450 X 769
SCZ-1010W6604	SCHNELL 4U 600/600 SINGLE SECTION CABINET	600 X 600 X 279
SCZ-1010W6609	SCHNELL 6U 600/600 SINGLE SECTION CABINET	600 X 600 X 368
SCZ-1010W6612	SCHNELL 9U 600/600 SINGLE SECTION CABINET	600 X 600 X 501
SCZ-1010W6615	SCHNELL 12U 600/600 SINGLE SECTION CABINET	600 X 600 X 635
SCZ-1010W6609	SCHNELL 15U 600/600 SINGLE SECTION CABINET	600 X 600 X 769